

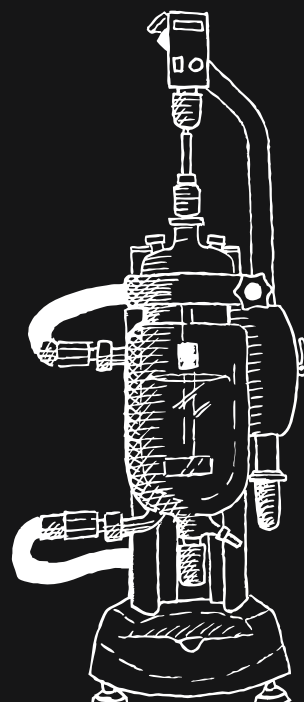

**SYRRIS**  
Orb

# Product information



Compact benchtop jacketed reactor  
offering ultimate ease of use

# Orb

Orb is a benchtop jacketed reactor system combining excellent value and high quality construction with unique, user-friendly features and reliable performance.

Designed for daily use, Orb's intuitive and thoughtful design makes it incredibly ease to use. Orb offers rapid height adjustment and two clamp sizes to accommodate a wide range of vessels from 100 mL to 10 L which

can be interchanged quickly. The system can be used over a wide temperature range for all your lab's chemistry needs. A wide selection of accessories and upgrades for automation are available.

[syrris.com/orb](https://syrris.com/orb)



# Why Orb?

Due to its modular design, wide vessel range, and wide temperature limits, Orb can be used in many applications including process development and optimization, advanced synthesis, crystallization, automated synthesis, and more.

Ease of use is Syrris' main design philosophy. Features include:

1. **Easy scale-up with a wide vessel range**
2. **Work at your height with easy, tool-free adjustment**
3. **Avoid spills with rapid oil pipe connection and oil drain**
4. **Quick clamp system for fast and safe vessel loading**
5. **Save lab space with one Orb frame for all vessels**
6. **Easy, simple, tool-free motor adjustment**

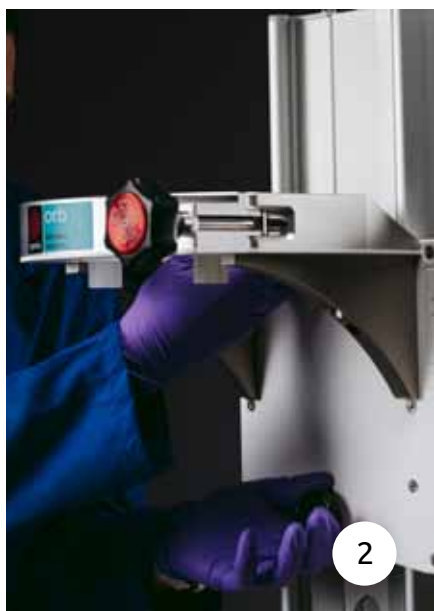





**“ Our passion is to design products to make chemists’ lives easier. The aim was to create a product with excellent performance at an attractive price.... and we believe Orb does this.”**

**Oliver Sowerby, Head of Product Design**



# Specifications

	Vessel range	100 mL to 10 L * / 100 mL to 5 L**
	Temp. range	-90 to 250 °C***
	Pressure range	Vacuum ( $\leq 50$ mbara****) to 250 mbar
	rpm	500 continuous / 800 intermittent
	Torque	Up to 200 Ncm

# Dimensions

	h (mm)	w (mm)	d (mm)
100 mL to 2 L vessels	975 <sup>^</sup>	406 <sup>^^</sup>	570
5 L vessels	1065 <sup>^</sup>	406 <sup>^^</sup>	570
10 L vessels	1245 <sup>^</sup>	406 <sup>^^</sup>	570

- \* Jacketed vessels
- \*\* Vacuum jacketed vessels
- \*\*\* Normal temperature range is -40 to 200 °C. Temperatures outside of this range require an upgrade kit.
- \*\*\*\* Lower vacuum is achievable with upgraded parts
- <sup>^</sup> Allow additional 80 mm for motor lifting.
- <sup>^^</sup> Please allow for oil pipes. Dimension is for system only.

All dimensions in mm. Please allow a tolerance of +/- 20 mm.

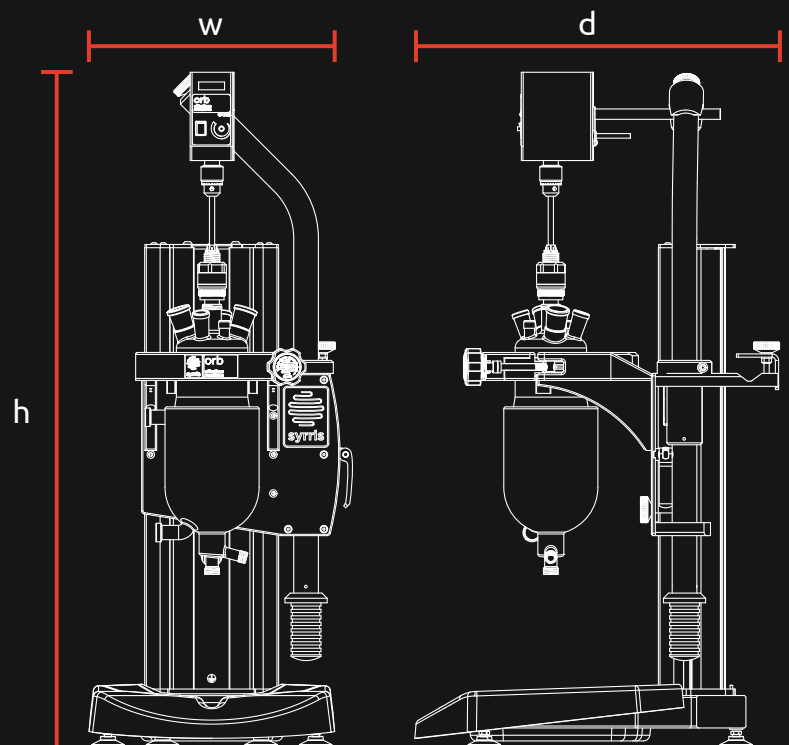

t: +44 (0)1763 242555 (UK)  
 t: 617 848 1211 (US)  
 t: 045-263-8211 (JP)  
 t: +91 (0)9892 327462 (IN)  
 e: info@syrris.com  
 w: syrris.com

# Vessels

## Torispherical (available with vacuum jacket)

	100 mL	250 mL	500 mL	1 L	1 L	2 L	2 L	3 L	5 L	10 L
Catalogue no.	2200997	2200996	2200995	2200994	2200993	2200992	2200991	2201138	2200990	2200989
Working capacity (mL)	100	250	500	1,000	1,000	2,000	2,000	3,000	5,000	10,000
Flange ID (mm)	100				150	100	150			
Internal diameter (mm)	51	69	83	105	105	130	130	140	170	205
External diameter (mm)	85	105	120	145	145	170	170	180	215	250
Depth to nominal vol. (mm)	54	80	97	122	122	159	159	205	235	315
Jacket volume (mL)	254	381	542	805	805	1169	1169	1484	2511	3805
Jacket connection thread	M16 x 1 (10 mm internal diameter)									
Outlet valve dia. (mm)	9				20	9	20			
Reactor material	Borosilicate glass 3.3									
Other wetted parts	PTFE, FEP, PFA & FFKM									

## Round-bottom

	100 mL	250 mL	500 mL	1 L	1 L	2 L	2 L	3 L	5 L	
Catalogue no.	2201006	2201005	2201004	2201003	2201002	2201001	2201000	2201137	2200999	
Working capacity (mL)	100	250	500	1,000	1,000	2,000	2,000	3,000	5,000	
Flange ID (mm)	100				150	100	150			
Internal diameter (mm)	51	69	83	105	105	140	140	145	175	
External diameter (mm)	85	105	120	145	145	185	185	185	215	
Depth to nominal vol. (mm)	58	80	107	133	133	153	153	207	238	
Jacket volume (mL)	254	381	542	805	805	1169	1169	1484	2511	
Jacket connection thread	M16 x 1 (10 mm internal diameter)									
Outlet valve dia. (mm)	9				20	9	20			
Reactor material	Borosilicate glass 3.3									
Other wetted parts	PTFE, FEP, PFA & FFKM									

# Lids

	DN100 (EU)	DN100 (US)	DN150 (EU)	DN150 (US)
Catalogue no.	2200982	2200981	2200980	2200979
Vessel compatibility	All DN100	All DN100	All DN150	All DN150
Flange ID (mm)	100	100	150	150
Center port	RV24	RV24	RV34	RV34
Condenser port	B29	A29	B29	A29
Solid addition port	B29	A29	B45	A45
Baffle ports	GL18	GL18	GL25/RV34*	GL25/RV34*
Probe ports	2 x B19	2 x A19	2 x B19	2 x A19

\* Dependent on baffles

# Components

<b>Base Frame</b>	The Orb Base Frame is a rugged and adaptable frame which accomodates all vessel sizes in the Orb family.
<b>Clamp</b>	The patent-pending Orb Clamp is available in two sizes (DN100 & DN150) and allows rapid vessel changes with safe sealing and support.
<b>Stirrer motors</b>	High-specification stirrer motors offer performance and durability for the most demanding applications.
<b>Lids</b>	The Orb Lid is available in two sizes (DN100 & DN150). Ports are included for baffles, solid addition, probes, and condensers, with custom options available.
<b>Baffles</b>	Orb baffles are available for all vessels to further improve mixing.
<b>Oil Pipe Tidy</b>	The Oil Pipe Tidy is easily attached to the main plate on the Orb clamp and allows leak-free storage of your oil pipes when changing vessels.
<b>Oil Drain Unit</b>	To limit mess when changing vessels, Orb has an optional Oil Drain Unit for easy and mess-free draining of vessel jackets.
<b>Stirrers</b>	Orb stirrers are available in anchor, Pitched Blade Turbine, and retreat curve impellor as standard. Also available are custom options as well as adjustable impellers.
<b>Outlet valves</b>	Syrris' spring-loaded outlet valves ensure leak-free operation at all tempature ranges. A range of seal kits are available for extreme temperatures.

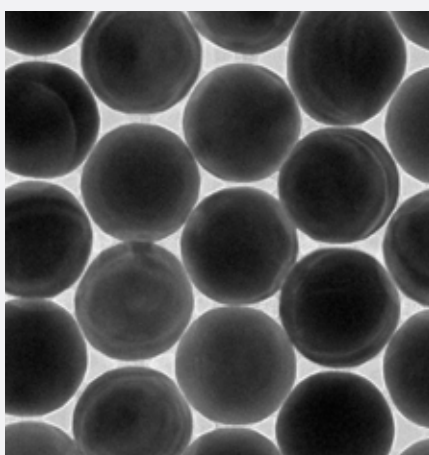

# Why choose Syrris?

## R&D

With 32 scientists and engineers and 2 R&D 100 Awards, the Syrris R&D team is comprised of world-leading experts in batch and flow chemistry, and calorimetry product development. To ensure products are finished to the highest quality, Syrris runs its development in a 4-phase system; each stage of development is checked by members of various teams.

In addition to continuous product improvement and development, the R&D Team regularly work with customers to create custom solutions tailored to the exact needs of the lab.

## Support

Syrris is on hand to help when you need it. From feasibility studies and proof of concept, through to on-site support by a Syrris engineer, our team are experienced chemists and are supported by a network of well-trained distributors in over 40 countries.

Built by our UK production team to the highest standard, with chemically resistant materials, Syrris products ensure years of continued service. A 1-year warranty as standard and the option to extend this further for complete peace of mind.

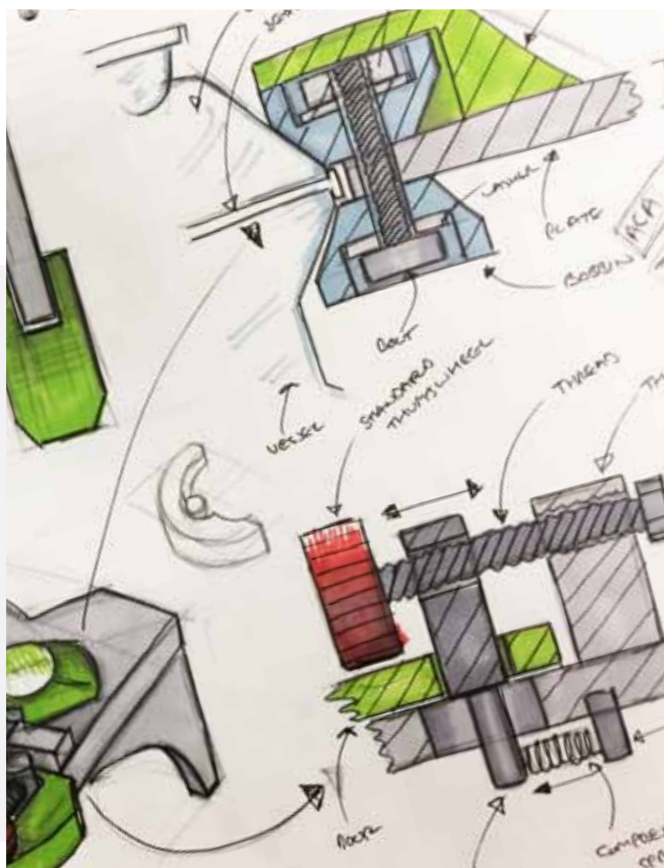

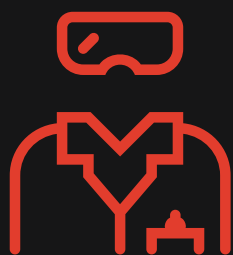

//

The Orb system is simple to operate, compact, & robust. My Masters and Doctoral students already have full autonomy to use the system"

Prof. Ricardo Aucélio, Pontificia Universidade Católica, Brazil

//

One key to our success with the system, apart from the strength of the product itself, is the highly responsive nature of Syrris as a company"

Dr. Sunil S. Nadkarni, VP, Product Development Torrent, India



# 350

## Publications

Syrris products have been cited in over 350 peer-reviewed publications, demonstrating their viability for real-world chemistry

# 40

## Distributors

Syrris works in partnership with over 40 distributors worldwide, offering expert knowledge and local support

# 1000s

## of Users

Thousands of chemists and chemical engineers use Syrris products in their ground-breaking research and development, including at the world's top 20 pharmaceutical, chemical, and food and fragrance companies

## Get in touch

**UK Head Office (Europe, S.E. Asia, Australasia, China, Middle East, Africa)**

t: +44 (0)1763 242555  
e: [info@syrris.com](mailto:info@syrris.com)  
w: [syrris.com](http://syrris.com)

**Japan Office**

t: +81 45 263 8211  
e: [info@syrris.co.jp](mailto:info@syrris.co.jp)  
w: [syrris.co.jp](http://syrris.co.jp)

**India Office**

t: +91 22 256 00 262  
e: [info@syrris.com](mailto:info@syrris.com)  
w: [syrris.com](http://syrris.com)

**North America Office**

t: +1 (617) 848 1211  
e: [info-usa@syrris.com](mailto:info-usa@syrris.com)  
w: [syrris.com](http://syrris.com)

**Brazil Office**

e: [info@syrris.com](mailto:info@syrris.com)  
w: [syrris.com.br](http://syrris.com.br)